

\* PART LISTED ARE STANDARD OPTIONS

Dwg. Ref.	Qty. Per	* Part Number	Part Name	Materials/Remarks
<b>SHELL</b>				
①	1	418091	Shell	Filament wound epoxy/glass composite. Head locking grooves integrally wound in place.
<b>HEAD</b>				
②	2	47471	Bearing Plate	Aluminium alloy 6061-T6 as per SB-221 ASME Edition 2015.
③	2	50481	Sealing Plate	Engineering Thermoplastic
④	2	45317	Head Seal	Ethylene Propylene - O-Ring
⑤	2	47469	Permeate Port	Engineering Thermoplastic
⑥	4	45299	Permeate Port Seal	Ethylene Propylene - O-Ring
⑦	2	45244	Port Retainer	PH 15-7 Mo Stainless Steel
⑧	2	47472	Feed/Conc. Port	UNS S32750 AS PER SA-790 ASME Edition 2015.
⑨	2	50489	Port Retainer Set	CF8M Cast SS, Two-piece set
⑩	2	45294	Adapter Seal	Ethylene propylene O-Ring
<b>HEAD INTERLOCK</b>				
⑪	2	45260	Retaining Ring	316 Stainless Steel as per SA-479 ASME Edition 2015.
<b>VESSEL SUPPORT</b>				
⑫	*2	45058	Saddle	Engineering Thermoplastic
⑬	*2	47459	Strap Assembly	304 Stainless Steel - Thermoplastic cushion
⑭	*4	97821	Strap Screw	5/16-18 UNC, 18-8 Stainless Steel
<b>ELEMENT INTERFACE</b>				
⑮	2	As Required	Adapter	Engineering Thermoplastic
⑯	A/R	As Required	PWT Seal	Ethylene propylene O-Ring

\*3 & \*6 each furnished with length code 4 & above.

RECOMMENDED SPAN BETWEEN SUPPORTS  
CENTER VESSEL ON 2 OR 3 SUPPORTS AT SPAN(S) "S": 3 SUPPORTS REQUIRED FOR LENGTHS -4 AND OVER

CAUTION: INCORRECT MANIFOLDING WILL CAUSE SEVERE LOCAL STRESS AROUND PORT AND MAY RESULT IN LEAKS AND PREMATURE FAILURE; TAKE EVERY PRECAUTION LISTED ON REVERSE, SEE INSTALLATION INSTRUCTIONS FOR FURTHER DETAILS

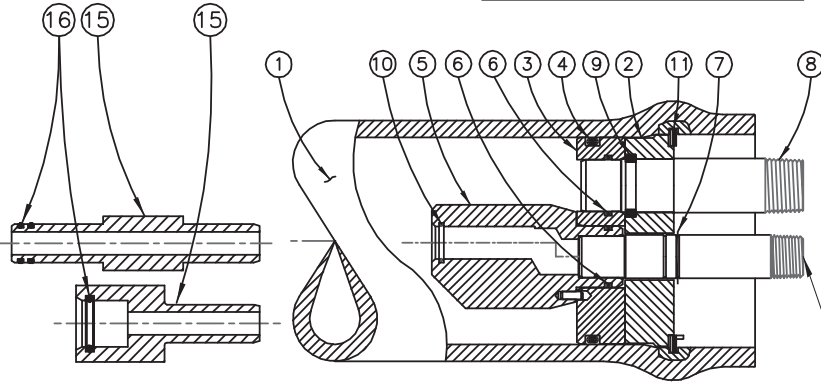

WARNING  
INTERNAL PORT PRESSURE NOT TO EXCEED 125 PSI

SECTION THROUGH END CLOSURE

- NOTES
- DIMENSIONS IN INCHES (MM APPROX).
  - NOT TO BE USED FOR CONSTRUCTION UNLESS CERTIFIED.
  - SHELL EXTERIOR COATED WITH WHITE RAL 9003, HIGH GLOSS POLYURETHANE PAINT.

Shell Length Code	L L.O.A. IN (MM)	S Span IN (MM)	F IN (MM)	APPROX. ASSEMBLY Weight LB (KG)
1	56.60 (1438)	28 X 1 (711)	54.10 (1374.7)	21 (9.5)
2	96.60 (2454)	56 X 1 (1422)	94.10 (2390.7)	31 (14.0)
3	136.60 (3470)	80 X 1 (2032)	134.10 (3406.7)	41 (18.6)
4	176.60 (4486)	64 X 2 (1626)	174.10 (4422.7)	51 (23.1)
5	216.60 (5502)	78 X 2 (1981)	214.10 (5438.7)	62 (27.8)
6	256.60 (6518)	92 X 2 (2337)	254.10 (6454.7)	71 (32.2)
7	296.60 (7518)	106 X 2 (2692)	294.10 (7470.7)	81 (36.7)

**PENTAIR**  
**CODELINE®**

**MODEL 40E100**  
HIGH PRESSURE MEMBRANE HOUSING

DRAWN	KR						
CHECKED	MD						
APPROVED	SS	ECN	DATE	SHEET	SIZE	NUMBER	REV
		4143	25JUL16	1 OF 2	B	518015	J

**RATING:**

DESIGN PRESSURE.....	1000 PSI (6.90 Mpa)
MAX. OPERATING TEMP.....	120°F (49°C)
MIN. OPERATING TEMP.....	20°F (-7°C)
FACTORY TEST PRESSURE.....	CE / ASME 1500 / 1100 PSI (10.34 Mpa) / (7.58 MPa)
BURST PRESSURE.....	6000 PSI (41.36 MPa)

**INTENDED USE:**

The CodeLine Model 40E100 Fiberglass RO Pressure Vessel is designed for continuous, long term use as housing for reverse osmosis membrane elements to desalt typical sea waters at pressures up to 1000 psi. Any make of four-inch nominal diameter spiral-wound element is easily accommodated; the appropriate interfacing hardware for the element specified is furnished with the vessel.

The CodeLine Model 40E100 is designed in accordance with the engineering standards of the Boiler and Pressure Vessel Code of the American Society of Mechanical Engineers (ASME Code) Edition 2015. At small additional cost, vessels can be inspected during construction by an ASME Authorized inspector and ASME Code stamped.

The CodeLine Model 40E100 must be installed, operated and maintained in accordance with the listed precautions and good industrial practice to assure safe operation over a long service life.

The high performance reinforced plastic shell must be allowed to expand under pressure; undue restraint at support points or piping connections can cause leaks to develop in the shell. The end closure, incorporating close fitting, interlocking metal components, must be kept dry and free of corrosion; deterioration can lead to catastrophic mechanical failure of the head.

The end closures, incorporating close-fitting, interlocking metal components, must be kept dry and free of corrosion; deterioration can lead to catastrophic mechanical failure of the heads.

Pentair will assist the purchaser in determining the suitability of this standard vessel for their specific operating conditions. The final determination however, including evaluation of the standard material of construction for compatibility with the specific corrosive environment, shall be the responsibility of the purchaser.

Specifications are subject to change without notice.

**PRECAUTIONS:**

- DO...read, understand and follow all instructions; failure to take every precaution will void warranty and may result in vessel failure
- DO...mount the shell on horizontal members at span "S" using complaint vessel supports furnished; tighten hold down straps just snug
- DO...provide overpressure protection for vessel set at not more than 105% of design pressure
- DO...inspect end closures regularly; replace components that have deteriorated and correct causes of corrosion

- DO NOT... make rigid piping connections to ports or clamp vessel in any way that resists growth of fiberglass shell under pressure; ΔDIA = 0.02 in. (0.5mm) and ΔL = 0.2 in. (5mm) for a length code -6 vessel
- DO NOT... hang piping manifolds from ports or use vessel in any way to support other components;
- DO NOT... operate vessel at pressures and temperatures in excess of its rating
- DO NOT... operate vessel without permeate ports internally connected with a complete set of elements and interconnecting hardware
- DO NOT... operate vessel with permeate pressure in excess of 125 psi at 120°F (0.9 MPa @ 49°C)
- DO NOT... overtighten the connection to the permeate port (hand-tighten plus one-quarter turn, check for leaks)
- DO NOT... tolerate leaks or allow end closures to be routinely wetted in any way
- DO NOT... pressurize vessel until double-checking to verify that the retaining ring is completely inside the groove
- DO NOT... work on any component until first verifying that pressure is relieved from vessel
- DO NOT... operate outside the pH range 3-11

For complete information on proper use of this vessel please refer to the 40E series USER'S GUIDE Bulletin 526005.

**ORDERING:**

Using the chart below, please check the features you require and fax them with your purchase order to our customer service department for expedited processing. For optional materials and/or features not listed below, please consult factory for pricing and availability.

Please note that we require your membrane brand and model number when ordering. If this information is not initially available, you may provide it at a later date by checking the appropriate box below.

**VESSEL LENGTH CODE – please check one**

MODEL 40E100  -1  -2  -3  -4  -5  -6  -7

**MEMBRANE BRAND AND MODEL – please check one and fill in information**

Please supply adapters for the following membrane brand and specific model  
Brand \_\_\_\_\_ Model \_\_\_\_\_

**CERTIFICATION REQUIRED– please check one**

- ASME Stamped and National Board Registered (please consult factory for pricing)  
ASME Section X Edition 2015.
- CE Marked.
- Standard, Certified by Pentair.

**EXTERIOR FINISH – please check one**

- Standard – white high-gloss RAL 9003 polyurethane coating.
- Option – optional colors are available for 50 or more vessels per order. Call factory for pricing details.

**MATERIAL AND PORT CONFIGURATIONS OPTIONS– please check one**

- Standard – All materials and port configurations as per drawing 518015 on the first page.
- Option – Feed/Concentrate port, ¾” IPS Grooved