

4 3 2 1

1200
PSI

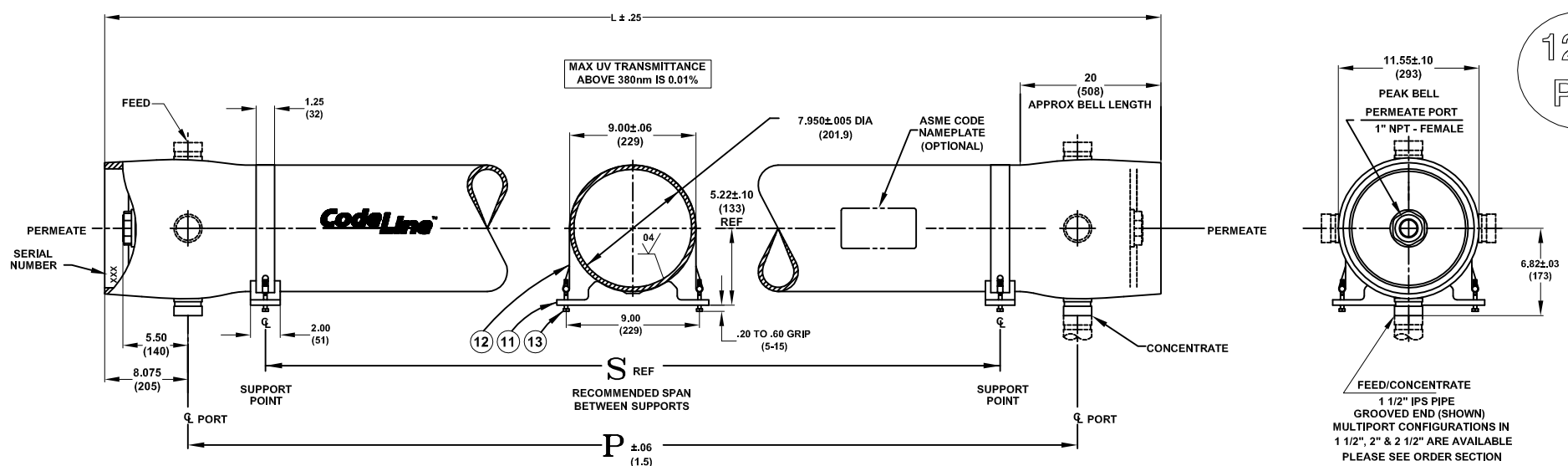

VIEW AT CENTER SUPPORT
 CENTER VESSEL ON 2 OR 3 SUPPORTS AT SPAN(S) "S" : 3 SUPPORTS REQUIRED FOR LENGTHS -4 AND OVER

CAUTION: INCORRECT MANFOLDING WILL CAUSE SEVERE LOCAL STRESS AROUND PORT AND MAY RESULT IN LEAKS AND PREMATURE FAILURE; TAKE EVERY PRECAUTION LISTED ON REVERSE, SEE INSTALLATION INSTRUCTIONS FOR FURTHER DETAILS

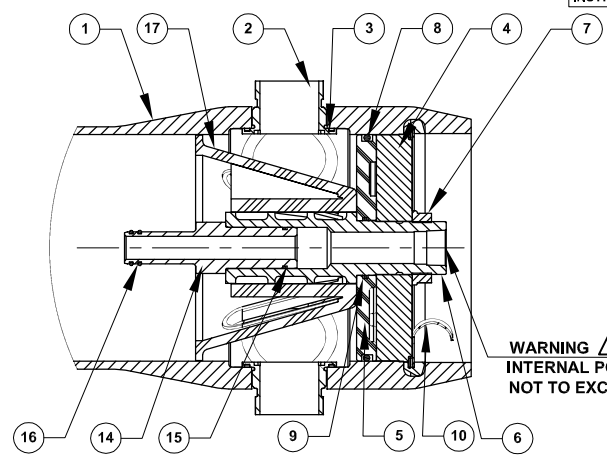

NOTES:-

- ♦ MAX. ANGULAR VARIATION BETWEEN ANY PORTS ±0.5°.
- ♦ DIMENSION IN INCHES (MM APPROX.)
- ♦ SHELL EXTERIOR COATED WITH WHITE, HIGH GLOSS POLYURETHANE PAINT.
- ♦ NOT TO BE USED FOR CONSTRUCTION UNLESS CERTIFIED.
- ♦ ITEM 17 DOWNSTREAM ONLY.
- ♦ GRADE CD3MWCuN AS PER ASME SA-995 (J93380).

Dash Length	L IN(MM)	P IN(MM)	S IN(MM)	Approx Weight LB(KG)
-1	63.15 (1604)	47 (1194)	19X1 (486)	170 (77)
-2	103.15 (2620)	87 (2210)	56X1 (1422)	214 (97)
-3	143.15 (3636)	127 (3226)	80X1 (2032)	258 (117)
-4	183.15 (4652)	167 (4242)	64X2 (1626)	303 (137)
-5	223.15 (5668)	207 (5258)	78X2 (1981)	347 (157)
-6	263.15 (6684)	247 (6274)	92X2 (2337)	391 (177)
-7	303.15 (7700)	287 (7290)	106X2 (2692)	435 (197)
-8	343.15 (8716)	327 (8306)	120X2 (3048)	484 (219)

DWG REF	QTY	PART NUMBER	DESCRIPTION	MATERIAL
SHELL				
1	1	ORDER SECTION	SHELL	Filament Wound Epoxy/Glass composites - Head locking grooves integrally wound in place.
2	A/R		F/C Port	CD3MWCuN *
3	A/R		F/C Port Seal	Ethylene Propylene
HEAD				
4	2	96158	Bearing Plate	6061-T6 Aluminium alloy - Hard anodized
5	2	96160	Sealing Plate	Engineering Thermoplastic.
6	2	96162	Permeate Port	Engineering Thermoplastic.
7	2	45066	Port Nut	Engineering Thermoplastic.
8	2	96000	Head Seal	Ethylene Propylene - O - Ring
9	2	45312	Perm Port Seal	Ethylene Propylene - O - Ring
HEAD INTERLOCK				
10	2	47336	Quick Release Spiral Ring	316 Stainless Steel.
VESSEL SUPPORT				
11	* 2	52169	Saddle	Engineering Thermoplastic.
12	* 2	45042	Strap Assy.	304 Stainless Steel-PVC Cushion.
13	4	46265	Strap screw.	5/16-18 UNC, 18-8 Stainless Steel.
ELEMENT INTERFACE				
14	2	A/R	Adapter	Engineering Thermoplastic.
15	2	52245	Adapter seal	Ethylene Propylene - O - Ring
16	4	A/R	PWT Seal	Ethylene Propylene - O - Ring
17	1	96163	Thrust Cone	Engineering Thermoplastic.

* 3 each furnished with length code 4,5,6,7 & 8.

DRAWN DATE	PGS 27 JAN 06			
CHECKED DATE	MD 27 JAN 06	CODELINE - 80S120 MEMBRANE HOUSING		
APPROVED DATE	RM 27 JAN 06	ECN 1750	DWG. NO. 99164	REV. G
		DATE 21 MAY 10	SCALE NONE	SIZE A3 SHEET 1 OF 2

4 3 2 1

RATING:

DESIGN PRESSURE.....1200 PSIG at 150°F
 (8.27 MPa at 66°C)
 MIN. OPERATING TEMP.....20°F
 (-7°C)
 FACTORY TEST PRESSURE..... CE / ASME
 1800 PSIG / 1320 PSIG
 (12.41 MPa) (9.10 MPa)

QUALIFICATION PRESSURE.....7200 PSI
 (49.64 MPa)

INTENDED USE:

The CodeLine 80S120 Fiberglass RO Pressure Vessel is designed for continuous, long term use as a housing for reverse osmosis membrane elements to desalt typical brackish and sea waters at pressures up to 1200 psi. Any make of eight-inch nominal diameter spiral-wound element is easily accommodated; the appropriate interfacing hardware for the element specified is furnished with the vessel.

The CodeLine 80S120 is designed in accordance with the engineering standards of the Boiler and Pressure Vessel Code of the American Society of Mechanical Engineers (ASME) Code. At small additional cost vessels can be inspected during construction by an ASME Authorized Inspector and ASME Code stamped.

The CodeLine 80S120 must be installed, operated and maintained in accordance with the listed precautions and good industrial practice to assure safe operation over a long service life.

The high performance Filament wound FRP shell must be allowed to expand under pressure; undue restraint at support points or piping connections can cause leaks to develop in the shell. This side-ported vessel requires special precautions in mounting and connection to piping so that the vessel will not be subjected to excessive stress due to bending moments acting at the side openings in the fiberglass shell. The end closure, incorporating close fitting, interlocking metal components, must be kept dry and free of corrosion; deterioration can lead to catastrophic mechanical failure of the head.

Pentair Water will assist the purchaser in determining the suitability of this standard vessel for their specific operating conditions. The final determination however, including evaluation of the standard material of construction for compatibility with the specific corrosive environment, shall be the responsibility of the purchaser. Alternate materials with enhanced corrosion resistance are available on special order.

Specifications are subject to change without notice.

PRECAUTIONS:

- DO...read, understand and follow all instructions; failure to take every precaution will void warranty and may result in vessel failure
- DO...mount the shell on horizontal members at span "S" using compliant vessel supports furnished Shim saddles if required. Tighten hold down straps just snug
- DO...align and center side ports with the manifold header. Correct, causes of misalignment in a row of vessels connected to the same header
- DO...use flexible type grooved-end pipe couplings, Victaulic® Style 77 or equal, at side ports; allow full, 0.125 inch gap between port and piping, and position piping to maximize flexibility of connection.
- DO...provide flexibility in, and support for piping manifolds so that vessel can grow in length under pressure without undue restraint; provide additional flexible joints in large pipes leading to manifold header.
- DO...provide overpressure protection for vessel set at not more than 105% of design pressure
- DO...inspect end closures regularly; replace components that have deteriorated and correct causes of corrosion
- DO... Lubricate seals sparingly, using nonpetroleum Based lubricants, i.e. Parker Super O-lube®, Glycerin or suitable silicone based lubricants.

- DO NOT...work on any component until first verifying that pressure is relieved from vessel
- DO NOT...make rigid piping connections to ports or clamp vessel in any way that resists growth of fiberglass shell under pressure; ***ΔDIA = 0.015 in. (0.4mm) and ***ΔL = 0.2 in. (6mm) for a length code -8 vessel
- DO NOT... hang piping manifolds from ports or use vessel in any way to support other components
- DO NOT...tighten Permeate Port connection more than one turn past hand tight
- DO NOT... operate vessel without connecting both Permeate Ports internally to complete set of elements or otherwise plug ports internally so that external piping connection is not subjected to feed pressure
- DO NOT...install Spacer on downstream end of vessel
- DO NOT...operate vessel without Thrust Cone installed downstream
- DO NOT...pressurize vessel until double-checking to verify that the Locking Ring is in place and fully seated.
- DO NOT...operate vessel at pressure and temperature in excess of its rating.
- DO NOT...operate vessel with permeate pressure in excess of 125 psi at 150°F (0.86 MPa at 66°C).
- DO NOT...tolerate leaks or allow end closures to be routinely wetted in any way
- DO NOT...operate outside the pH range 3-10.

Note: This vessel can be operated at 190°F (88°C) upto 600 psi (4.1 MPa)

ORDERING:

Using the chart below, please check the features you require and fax them with your purchase order to our customer service department for further processing. For optional materials and / or feature not listed below, please consult the factory for pricing and availability

VESSEL LENGTH CODE – please check one

MODEL 80S120 -1 -2 -3 -4 -5 -6 -7 -8

MEMBRANE BRAND AND MODEL – please check one and fill in information

- Please supply adapters for the following membrane brand and specific model
 Brand _____ Model _____
- Membrane brand and model information is not currently available, but will be supplied to Pentair Water on or before the following date. ___ / ___ / ___

CERTIFICATION REQUIRED

- ASME Stamped and National Board Registered (please consult factory for pricing)
- CE Marked.
- Standard, Certified by Pentair water.

MATERIAL OPTIONS – please check one

- Standard: all materials as per drawing 99164 on the previous page
 NOTE: The options listed below will increase the vessel price. Call factory for pricing details.
- Option: Customer specified Material of Construction.(Please consult factory as these options will affect pricing and vessel lead time)

FEED/CONCENTRATE PORT CONFIGURATION

- Standard – 1½" IPS pipe, grooved ends, with ports in-line
- Optional – Multi-Ports™
 Using the instructions in Order Specification Sheet #99007 please fill out your feed port configuration in the space below. List port location first, followed by port size for each choice. 1.5", 2", 2.5" Ports not available in 90° configurations.

Serial number end
 Opposite end

PERMEATE PORT CONFIGURATION

- Standard 1" FNPT.
- Optional – 1.25" MNPT.

For complete information on proper use of the vessel
 Please refer to the 80S Series USER'S GUIDE 94182.

PORT SIZE CODE	
D	1½" GROOVED END
E	2" GROOVED END
F	2½" GROOVED END

